

Analog Devices Welcomes Hittite Microwave Corporation

NO CONTENT ON THE ATTACHED DOCUMENT HAS CHANGED



THIS PAGE INTENTIONALLY LEFT BLANK

GaAs MMIC SUB-HARMONICALLY PUMPED MIXER, 28 - 40 GHz

Typical Applications

The HMC259 is ideal for:

- Point to Point Radios
- LMDS
- SATCOM

Functional Diagram

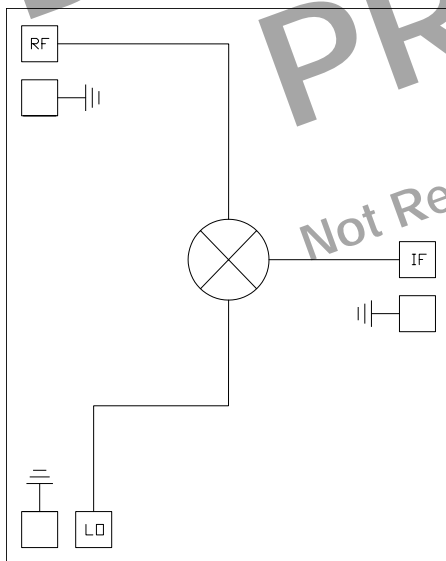

Features

- Sub-Harmonically Pumped (x2) LO
- High 2LO/RF Isolation: >35 dB
- Small Size: 1.24mm x 1.55mm

General Description

The HMC259 chip is a broadband sub-harmonically pumped (x2) balanced MMIC passive mixer which can be used as an upconverter or downconverter. The chip utilizes a GaAs MESFET process resulting in a small overall chip area of 1.9mm². This chip has a very wide IF bandwidth of DC-13 GHz. The 2LO to RF isolation is excellent eliminating the need for additional filtering. All data is with the chip in a 50 ohm test fixture connected via 0.025mm (1 mil) diameter wire bonds of minimal length <0.31mm (<12 mils). This device is a much smaller and more reliable replacement to hybrid diode mixer designs.

5

MIXERS - CHIP

Electrical Specifications, $T_A = +25^\circ C$, LO Drive = +15 dBm

Parameter	IF = 1 GHz			IF = 1 GHz			Units
	Min.	Typ.	Max.	Min.	Typ.	Max.	
Frequency Range, RF	28 - 40			36 - 40			GHz
Frequency Range, LO	14 - 20			18 - 20			GHz
Frequency Range, IF	DC - 12			DC - 4			GHz
Conversion Loss		14	17		12	15	dB
Noise Figure (SSB)		14	17		12	15	dB
2LO to RF Isolation	28	35		40	50		dB
2LO to IF Isolation	58	65		63	68		dB
RF to IF Isolation	25	30		25	32		dB
LO to IF Isolation	10	15		12	17		dB
IP3 (Input)	2	5		2	6		dBm
1 dB Compression (Input)	-7	-4		-7	-1		dBm

*Unless otherwise noted, all measurements performed as downconverter, IF= 1 GHz.

GaAs MMIC SUB-HARMONICALLY PUMPED MIXER, 28 - 40 GHz

Conversion Gain vs. Temperature @ LO = +15 dBm

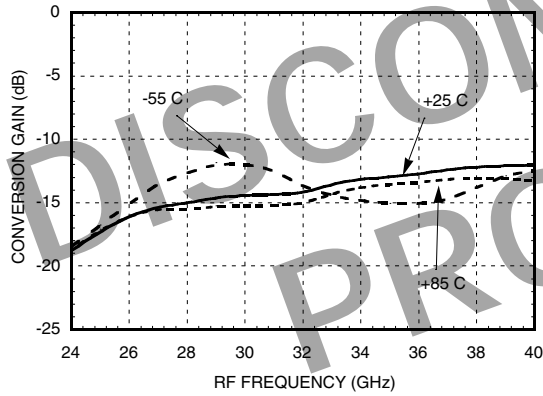

Isolation @ LO = +15 dBm

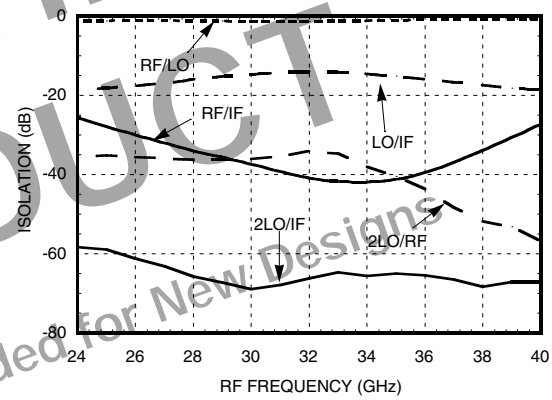

Conversion Gain vs. LO Drive

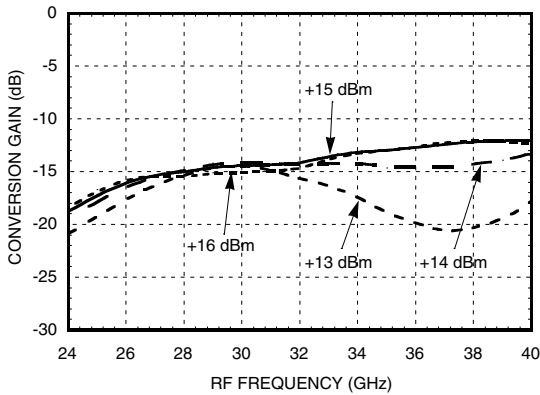

Return Loss @ LO = +15 dBm

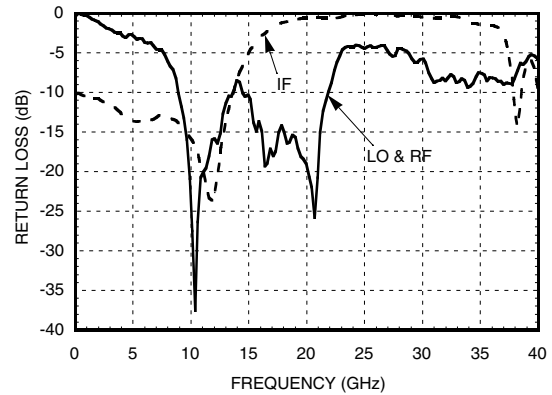

IF Bandwidth @ LO = +15 dBm

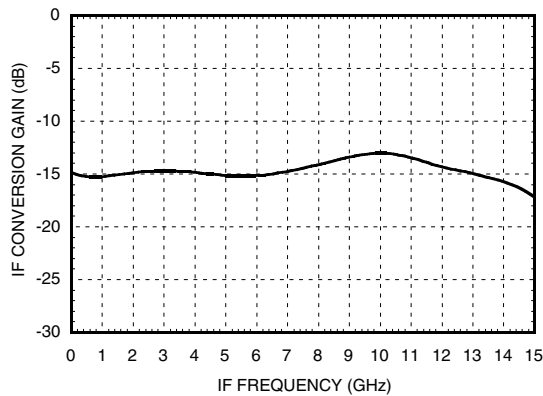

Upconverter Performance Conversion Gain @ LO = +15 dBm

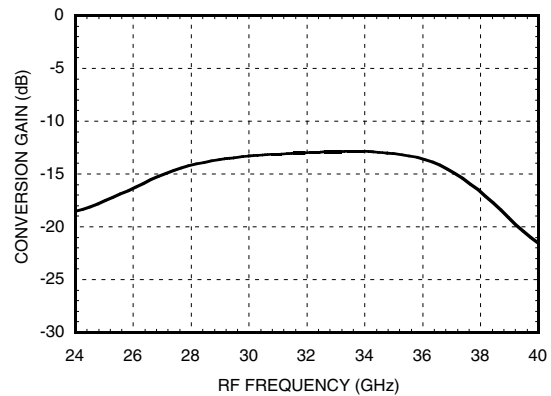

GaAs MMIC SUB-HARMONICALLY PUMPED MIXER, 28 - 40 GHz

Input IP3 vs. LO Drive

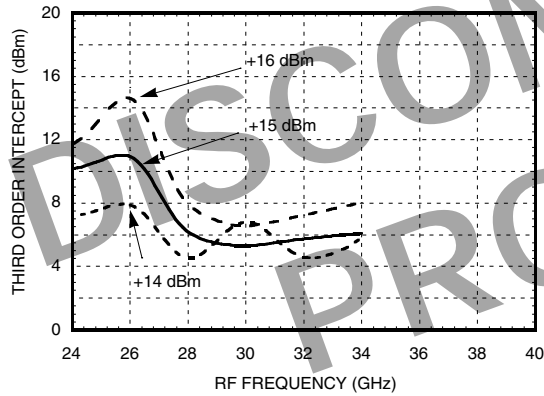

Input IP3 vs. Temperature @ LO = +15 dBm

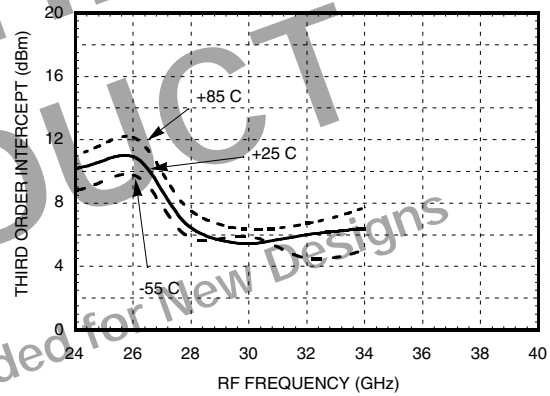

Input IP2 vs. LO Drive

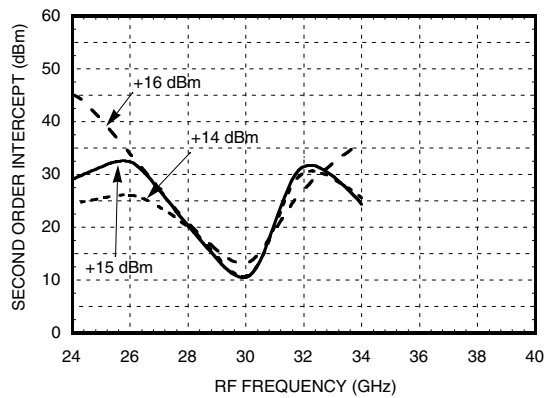

Input IP2 vs. Temperature @ LO = +15 dBm

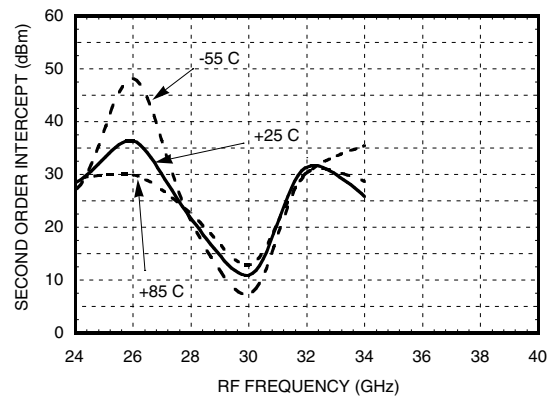

MxN Spurious Outputs

mRF	nLO					
	±5	±4	±3	±2	±1	0
-3						
-2	-37					
-1	-46	-48	-22			
0				-28	+29	
1				x	-24	-29
2		-40	-44	-81		
3	-76					

RF = 30 GHz @ -15 dBm
 LO = 14 GHz @ +15 dBm
 All values in dBc below the IF power level

P1dB vs. Temperature @ LO = +15 dBm

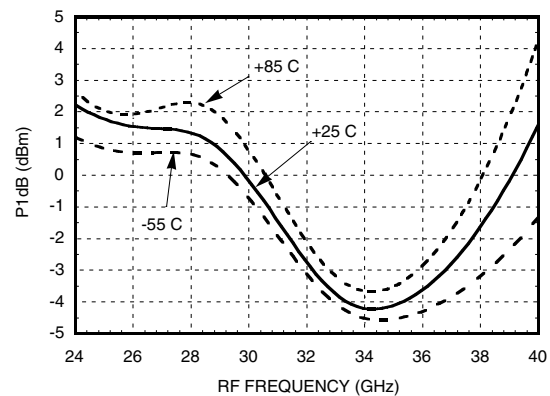

GaAs MMIC SUB-HARMONICALLY PUMPED MIXER, 28 - 40 GHz

Absolute Maximum Ratings

RF / IF Input	+13 dBm
LO Drive	+23 dBm
Storage Temperature	-65 to +150 deg C
Operating Temperature	-55 to +85 deg C

Outline Drawing

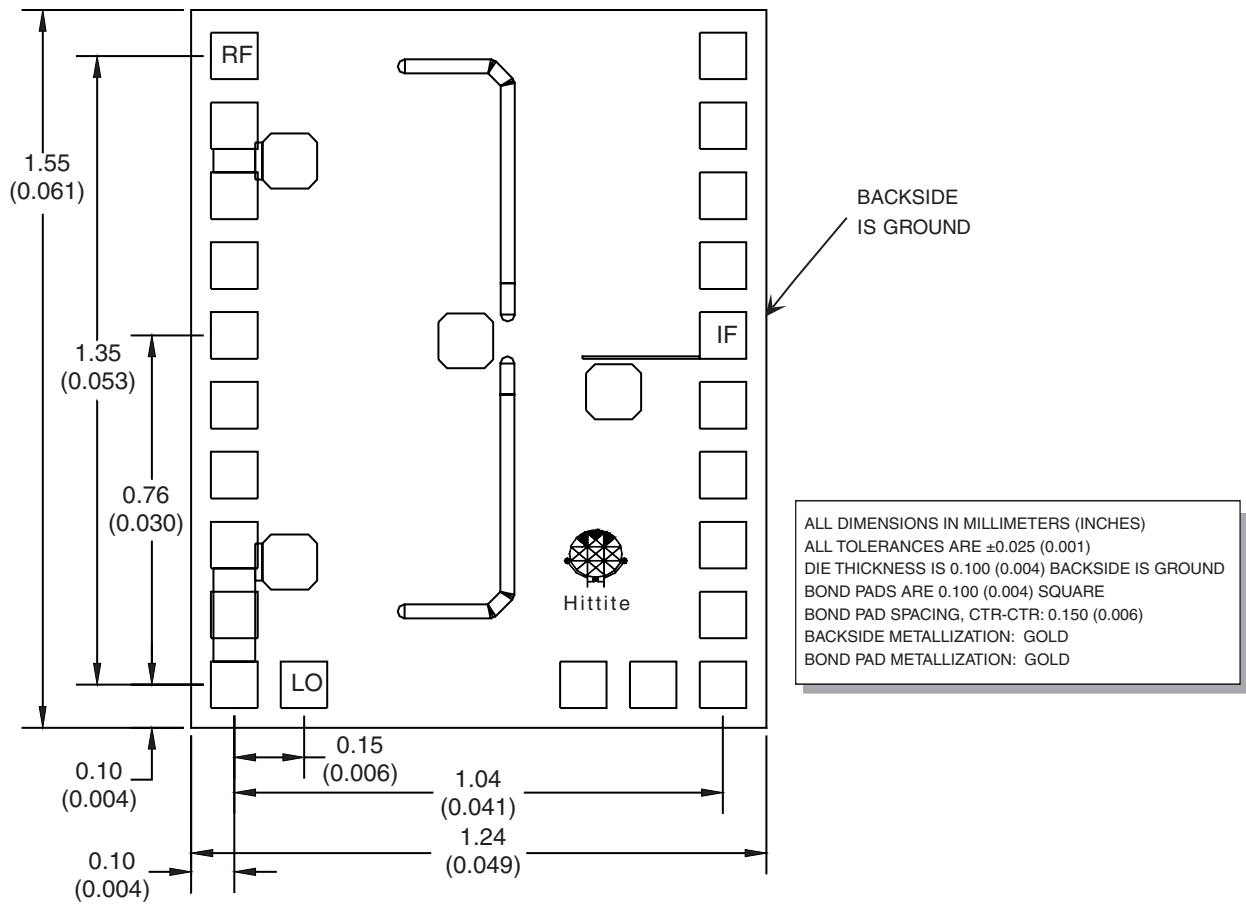

GaAs MMIC SUB-HARMONICALLY PUMPED MIXER, 28 - 40 GHz

MMIC Assembly Techniques for HMC259

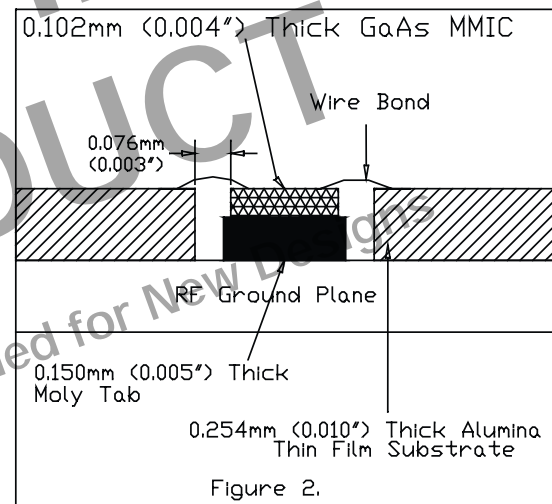
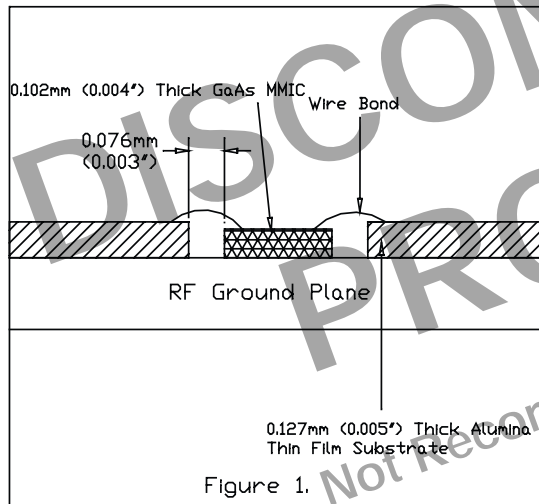

Mounting & Bonding Techniques for Millimeterwave GaAs MMICs

The die should be attached directly to the ground plane eutectically or with conductive epoxy (see HMC general Handling, Mounting, Bonding Note).

50 Ohm Microstrip transmission lines on 0.127mm (5 mil) thick alumina thin film substrates are recommended for bringing RF to and from the chip (Figure 1). If 0.254mm (10 mil) thick alumina thin film substrates must be used, the die should be raised 0.150mm (6 mils) so that the surface of the die is coplanar with the surface of the substrate. One way to accomplish this is to attach the 0.102mm (4 mil) thick die to a 0.150mm (6 mil) thick molybdenum heat spreader (moly-tab) which is then attached to the ground plane (Figure 2).

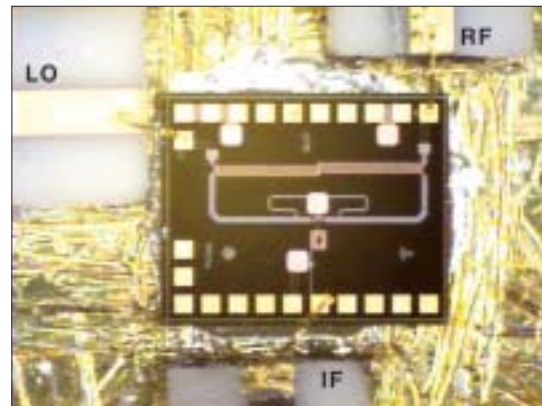

Figure 3: Typical HMC259 Assembly

Microstrip substrates should be brought as close to the die as possible in order to minimize bond wire length. Typical die-to-substrate spacing is 0.076mm (3 mils).

**GaAs MMIC SUB-HARMONICALLY
PUMPED MIXER, 28 - 40 GHz****Handling Precautions**

Follow these precautions to avoid permanent damage.

Cleanliness:

Handle the chips in a clean environment.
DO NOT attempt to clean the chip using liquid cleaning systems.

Static Sensitivity:

Follow ESD precautions to protect against $> \pm 250V$ ESD strikes.

Transients:

Suppress instrument and bias supply transients while bias is applied.
Use shielded signal and bias cables to minimize inductive pick-up.

General Handling:

Handle the chip along the edges with a vacuum collet or with a sharp pair of bent tweezers.
The surface of the chip has fragile air bridges and should not be touched with vacuum collet, tweezers, or fingers.

Mounting

The chip is back-metallized and can be die mounted with AuSn eutectic preforms or with electrically conductive epoxy. The mounting surface should be clean and flat.

Eutectic Die Attach:

A 80/20 gold tin preform is recommended with a work surface temperature of 255 deg. C and a tool temperature of 265 deg. C. When hot 90/10 nitrogen/hydrogen gas is applied, tool tip temperature should be 290 deg. C.

DO NOT expose the chip to a temperature greater than 320 deg. C for more than 20 seconds. No more than 3 seconds of scrubbing should be required for attachment.

Epoxy Die Attach:

Apply a minimum amount of epoxy to the mounting surface so that a thin epoxy fillet is observed around the perimeter of the chip once it is placed into position.

Cure epoxy per the manufacturer's schedule.

Wire Bonding

Ball or wedge bond with 1.0 diameter pure gold wire. Thermosonic wirebonding with a nominal stage temperature of 150 deg. C and a ball bonding force of 40 to 50 grams or wedge bonding force of 18 to 22 grams is recommended. Use the minimum level of ultrasonic energy to achieve reliable wirebonds. Wirebonds should be started on the chip and terminated on the package or substrate. All bonds should be as short as possible $<0.31\text{mm}$ (12 mils).